

# Alrouf LED Medium-intensity Solar Powered Aircraft Warning Light



## Products Description

### Medium-intensity Type A Solar Aviation Obstruction Light

Medium-intensity Type A Solar Aviation Obstruction Light adopts low-light but high efficient solar panels integrated design, cooperate with solar dedicated lithium iron phosphate battery as power supply. The battery adopts advance power management system, which can provide good protection when battery 's voltage and temperature too high or too low, so it can improve the battery's service life efficiently. Control circuit adopts micro-power consumption, which reduce controlling circuit 's power consumption.

Light source adopts high efficient LED chip, which has specific of high light intensity, low power consumption ,long service life and so on.

The Product's shell adopts portable structure design.It's very convenient for installation and transportation.

Lampshade adopts PC material, which has strong ability of corrosion, anti-UV, anti-shock.

## Features

- Continuous working time in rainy day can reach more than 18 days (12 hours a day) .
- Photocell can switch ON/OFF the light in rainy days or at night automatically.
- Can customize both lamp flashing synchronously or alternately.
- Standardization of optical design, high photoelectric conversion efficiency.
- Adopts special customized LED chip,transfer efficiency and service life is higher than normal LED.
- Provide ability of lightning protection, light fastness, resist snow and rain.
- Inner adopts replaceable solar lithium iron phosphate battery, whose service life can above 5 years.



## Specification

Name	Parameter	Name	Parameter
Type	ARG-MS/A	Light Source Life	>100000 hours
Power Provider	Mono-Crystalline Silicon Solar panel	Emitting Colors	White
Battery Capacity	12V24AH	Battery Type	Lead acid battery
Battery lifespan	2years	Solar panel voltage	16.5V
Solar panel Power	8Wx4	Solar panel lifespan	>20years
Power Consumption	≤45W	Vertical Divergence	>10°
Visual Distance	40km	Horizontal Out-put	360°
FAA Classify	L865	Overall Size(mm)	325X325X366
Light Source	LED	Installation Size(mm)	270mm×M8
Working temperature	-40°C~50°C	Wind-speed Ability	80m/s
Storage temperature	-40°C~70°C	Working mode	Flashing(40tims/min)
Sun Switch Illumination Threshold	300LUX±100LUX	Light Intensity	2000cd~20000cd (±25%)
Continuous Burning Timein rainy days	>20 days (12 hours/day)	IP Protection	IP65
Weight	18kg		

## Dimension

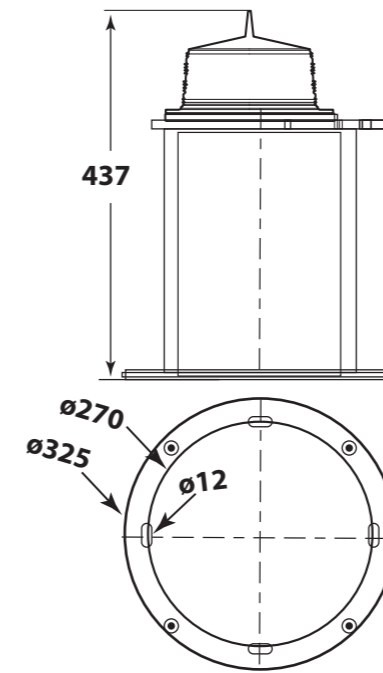

## Application

Block,
Bridge,
Towers,
Communication tower,
Chimney,
Runway,
Heliport,
Traffic barrier,
Tower cranes