

GS-HP/F Flood Light

GS-HP/F Flood light adopts full sealed aluminum shell. Protection standard is IP65.

Light source uses LED with high-efficiency and low attenuation, which has illumination uniformity angle.

The drive adopts the international famous brand Meanwell power supply.

This is an industrial lamp specially designed for helipad lighting.

Features

- With work stability, anti - electromagnetic radiation, anti - vibration, suitable for radar dense area.
- Full sealed structure base, with superior waterproof performance.
- With the anti-surge protection device.
- CREE LED chips, with high light brightness and long service life.
- Built - in Meanwell drive.
- Lightweight design of aviation grade materials, suitable for all kinds of helicopter SOS rescue equipment transport.
- Adopts easy to fold and replaceable mounting base.
- Adopts the toughened glass smooth, provides corrosion resistance and UV protection.



GS-HP/F

Dimension

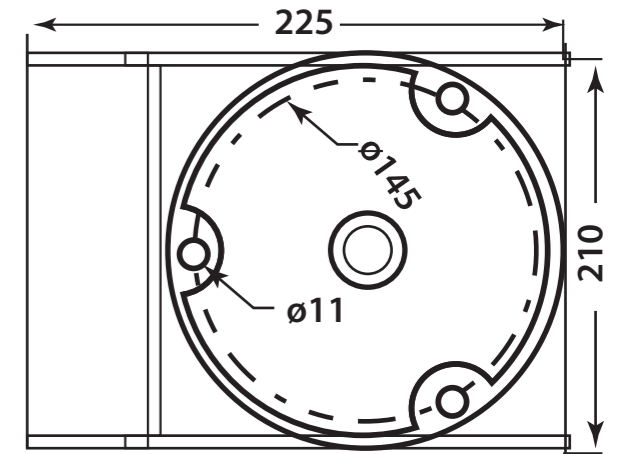
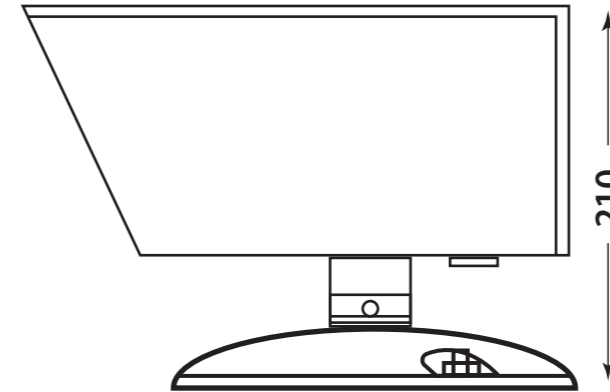

Specification

Name	Parameter
Model	GS-HP/F
Power voltage	AC85~264V, 6.6A, DC48V, DC24V
Light Source	CREE chips LED
Optical structure	Reflective optical structure
Power Consumption	20-50W
Working mode	Steady Burning
Luminous Flux	6000~8000Lm
Emitting Light Colors	White
Overall Size(mm)	255x 165 x 158(mm)
Installation size	∅ 145mm x M8 (3 holes)
IP Protection	IP65
Ambient Temperature	-50°C~70°C
Net Weight	3.5KG
Humidity	<95%
Altitude	<4500M